

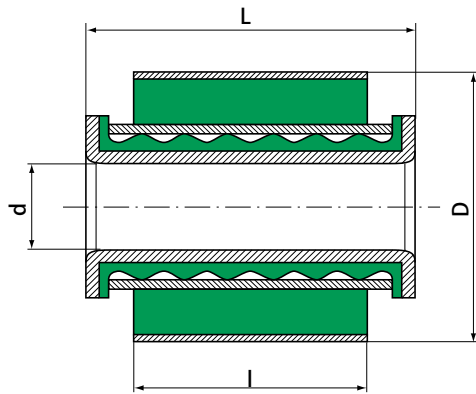

PIVOT BUSHES

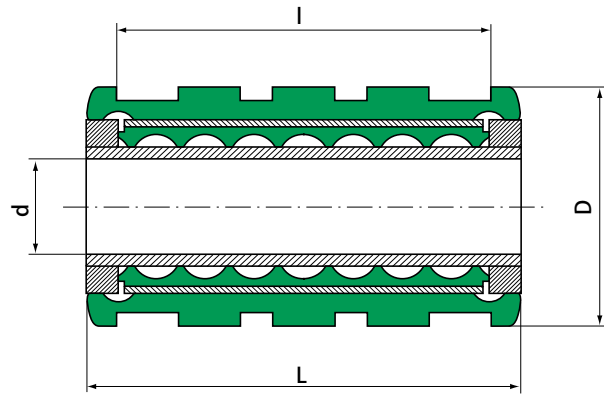

Shape 1



Shape 2

FLUIDBLOC® AND TOURIFLEX®

These are high precision bushes; they are made of injected polyurethane and can resist oil, water, ozone, etc.

These “PIVOTING” bushes are characterised by their very low torsional resistance (0.1 to 0.2 N.m). They can ensure a complete rotation (360°), and have no requirements for maintenance because they have a permanent lubricant.

They don't need a high precision housing, and the load to remove the bushes is between 1500 and 1800 daN.

There are many applications, such as :

Leaf spring bushes for vehicles not exceeding 5 tons.

d (mm)	D (mm)	l (mm)	L (mm)	Maximum radial load static daN	fig.	Reference
16	36	60	70	900	2	566050
16	45	60	70	1100	2	566051
SQUARE AXIS	140	214	304	7000	-	568256
27	70	60	76	1000	1	568247
36	88	70	86	1000	1	568248

1kg ≈ 1daN