

S.C. MOUNTS

Natural frequency : (1)
6 to 30 Hz

DESCRIPTION

The S.C. mount comprises an annular section bonded between the inner tube and outer housing. The outer housing has a mounting flange (4 different types).

OPERATION

The design of the S.C. mount gives the following basic characteristics :

- Axial elasticity four times higher than radial elasticity.
- The rubber works in shear.
- Progressive buffer against shocks or accidental overload, provided that a large metal washer is used to bear against the rubber dome.
- Can be used as a fail safe assembly when fitted as in shape 1.

Advantages :

- Extensive range: 3 hardnesses of rubber for 20 existing types, allowing the mounting to be optimised as a function of the load and exciting frequency.

Recommendations :

- In order not to affect the performance of the mounting system, all external connections must be flexible.
- S.C. mounts must be fitted so that the vibration input is in the axial direction.

(1) Natural frequencies with max/min loads, see : OPERATING CHARACTERISTICS.

DIMENSIONS

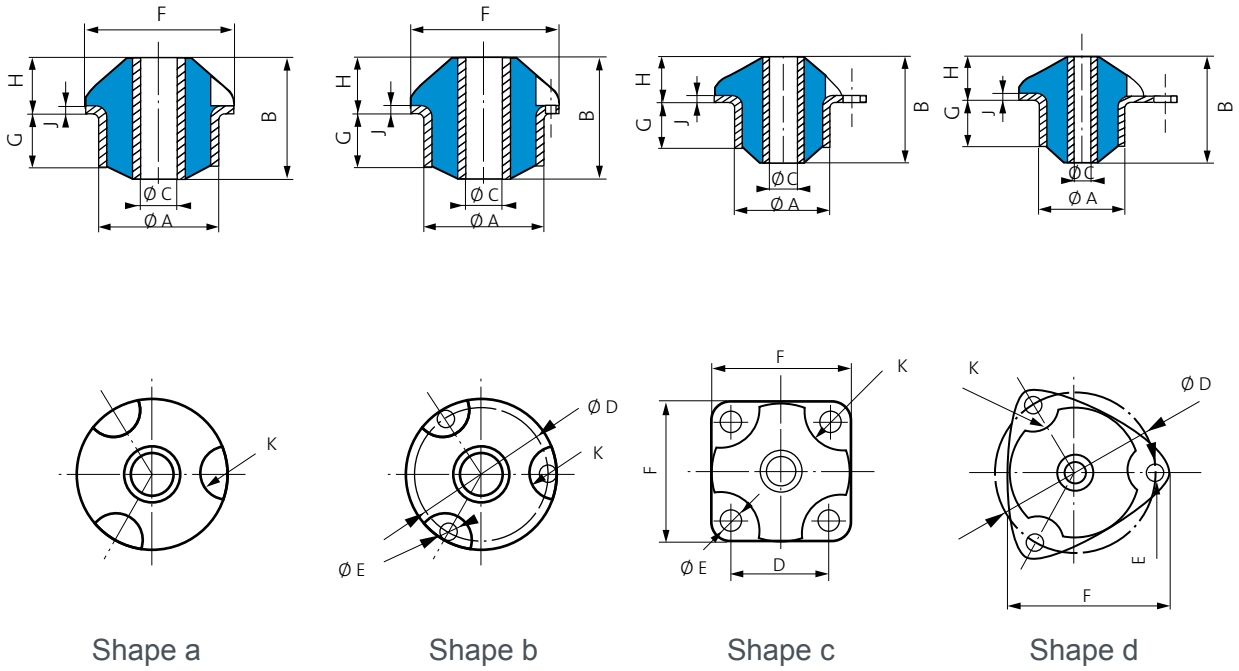

Shape a

Shape b

Shape c

Shape d

TYPE	Reference		Ø A (mm)	B (mm)	Ø C (mm)	Ø D (mm)	E (mm)	F (mm)	G (mm)	H (mm)	J (mm)	K (mm)	Weight (g)		
	With fixing holes	Without fixing holes													
S.C. 000	531201	Shape c	-	-	20	11	6,2	19	3,2	25	3	7	1	4	8
S.C. 00	531301	Shape c	-	-	26	28	8	26	5,2	36	12,5	11,5	1,5	12	40
S.C. 01	-	-	531401	Shape a	37,5	40	12,1	-	-	48	18	18	2	8	110
S.C. 02	-	-	531402	Shape a	37,5	51	12,1	-	-	48	24	18	2	8	130
S.C. 10	531216	Shape d	-	-	49,1	47	12,2	69	8,2	72	20	18	2	12	190
S.C. 11	531611	Shape d	-	-	49,1	60	12,2	69	8,2	72	31	18	2	12	290
S.C. 20	-	-	531701	Shape a	55,7	55	18,2	-	-	70	27	19	3	10	370
S.C. 21	-	-	531702	Shape a	55,7	70	18,2	-	-	70	39	19	3	18	480
S.C. 21	531240	Shape d	-	-	57,2	70	18,2	86	10,5	90	39	19	3	18	500
S.C. 30	531259	Shape b	-	-	65	75	20,2	78	8,5	90	29	28	3	18	560
S.C. 31	531261	Shape d	-	-	66,5	93	20,2	95	8,5	107	47	28	3	18	780
S.C. 40	531714	Shape d	-	-	76	90	22,2	100	8,5	112	42	28	3	18	880
S.C. 41	531327	Shape d	-	-	76	110	22,2	100	8,5	112	49	28,5	3	18	960
S.C. 41	-	-	531902	Shape a	74	110	22,2	-	-	100	49	28	3	18	960
S.C. 50	531939	Shape d	-	-	87,5	100	40,2	114	8,5	127	47	33	3	20	1300
S.C. 51	531947	Shape b	-	-	86	120	40,2	104	10,5	120	63	33	4	22	1500
S.C. 70 réd.	531933	Shape b	-	-	118	98	60,2	145	10,5	164	36	46	4	22	2200
S.C. 70	531932	Shape b	-	-	118	140	60,2	145	10,5	164	66	46	4	22	3000
S.C. 71	531931	Shape b	-	-	118	170	60,2	145	10,5	164	96	46	5	30	3800
S.C. 80	531940	Shape b	-	-	170	167	80	204	12,2	230	95	53	5	30	7100
S.C. 81	531941	Shape b	-	-	170	185	80	204	12,2	230	113	53	5	30	7700

See current price list for availability of items.

OPERATING CHARACTERISTICS

Nominal static load (daN)	Deflect. (mm)	Reference	Hard. Shore A
1-6	1	531201	45
2-8	0,8	531201	60
2-10	0,5	531201	75
5-20	1,5	531301	45
7-30	1,2	531301	60
10-40	0,8	531301	75
10-50	2,5	531401	45
15-65	1,8	531401	60
15-65	2,5	531402	45
15-70	4	531216	45
20-80	1,5	531401	75
20-85	1,8	531402	60
20-85	4	531611	45
25-100	3	531216	60
25-100	3,5	531701	45
25-110	1,5	531402	75
30-120	2	531216	75
30-120	3	531611	60
30-135	3,5	531240	45
30-135	3,5	531702	45
35-150	1,5	531611	75

Nominal static load (daN)	Deflect. (mm)	Reference	Hard. Shore A
35-150	3	531701	60
40-175	5	531259	45
45-180	2	531701	75
45-190	3	531240	60
45-190	3	531702	60
55-225	5	531714	45
60-240	3,5	531259	60
60-250	2	531240	75
60-250	2	531702	75
60-250	5	531261	45
60-250	5	531327	45
60-250	5	531902	45
75-300	2	531259	75
80-320	4,5	531714	60
80-325	4,5	531939	45
85-350	3,5	531261	60
90-360	4,5	531327	60
90-360	4,5	531902	60
95-380	3	531714	75
100-400	4,5	531947	45
105-420	2	531261	75

Nominal static load (daN)	Deflect. (mm)	Reference	Hard. Shore A
110-450	3,5	531939	60
110-450	3	531327	75
110-450	3	531902	75
110-450	6,5	531933	45
135-550	2,5	531939	75
135-550	3,5	531947	60
150-600	5	531933	60
165-670	2,5	531947	75
175-700	6,5	531932	45
210-850	6,5	531931	45
225-900	5	531932	60
275-1100	3	531932	75
275-1100	5	531931	60
310-1250	11	531940	45
350-1400	3	531931	75
400-1600	11	531941	45
450-1800	8,5	531940	60
525-2100	8,5	531941	60
575-2300	5	531940	75
650-2600	5	531941	75

LOAD/DEFLECTION CURVES IN AXIAL COMPRESSION

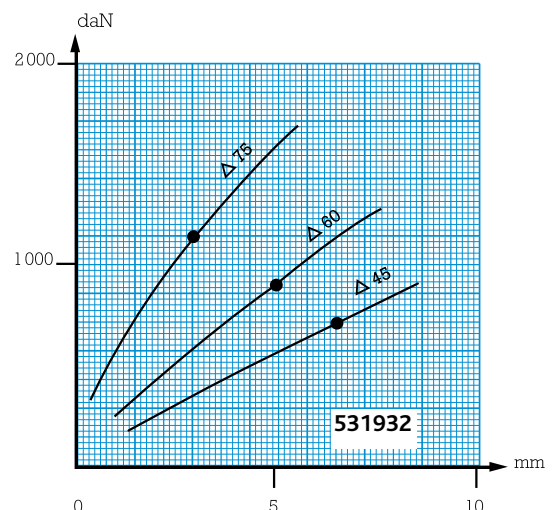
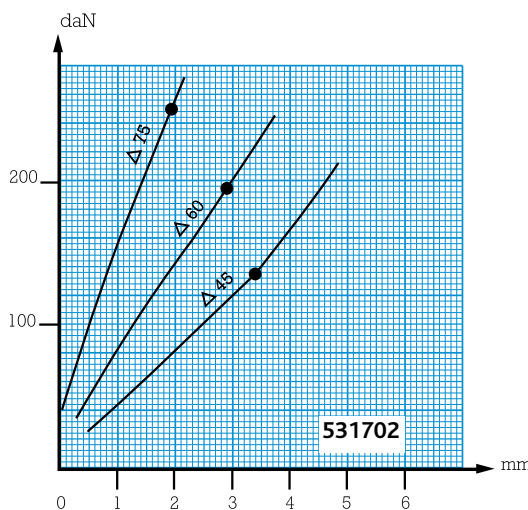
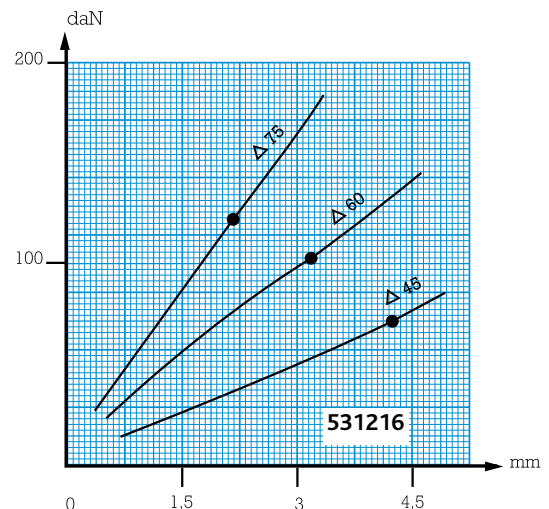
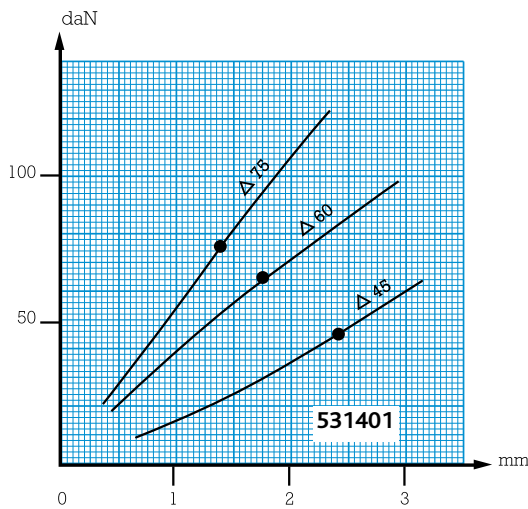

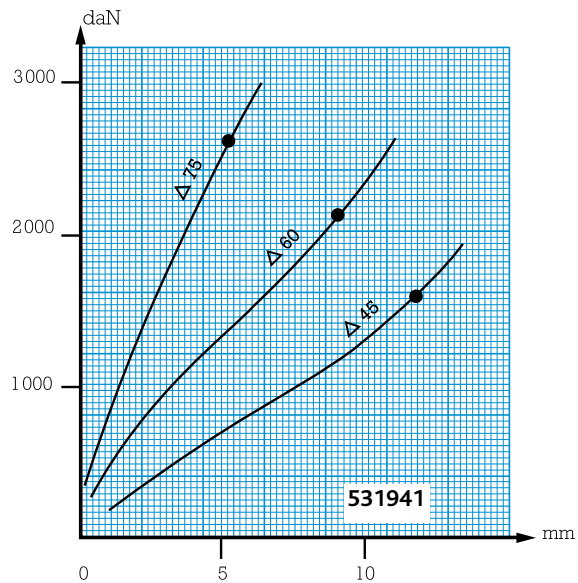
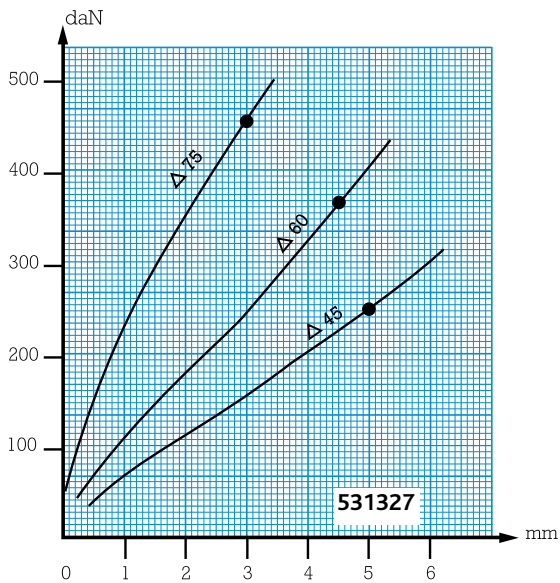

ASSEMBLY

Standard Installations

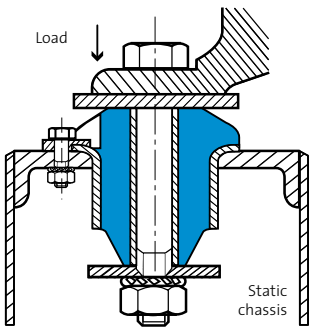

Shape 1 - Fixing between the equipment and a metallic chassis (failsafe in mobile applications).

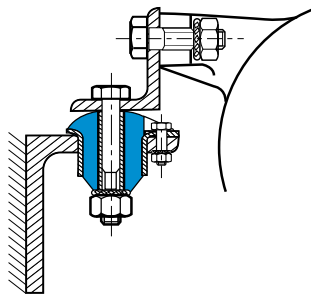

Shape 2 - Fixing between two brackets onto a vertical surface (non failsafe).

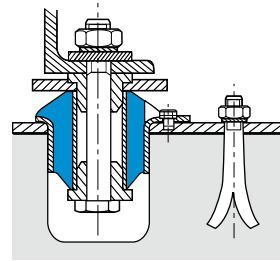

Shape 3 - Fixing between the equipment and concrete (using locating rings).

Reversed Installations

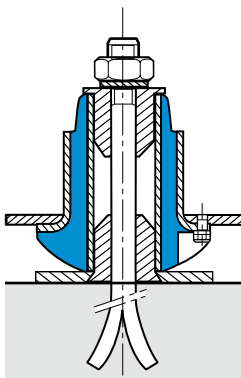

Shape 4

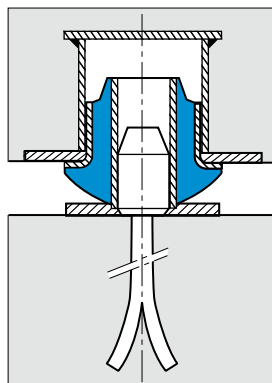

Shape 5 - Fixing between inertia base and foundation. The inertia base increases the suspended mass and thus reduces the amplitudes of the vibrations as well as lowering the natural frequency.

Tandem Mounting

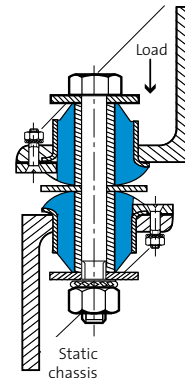

Shape 6 - Two mounts fixed face to face. Provides twice the deflection under the same load.