

S.T. C

Natural frequency : (1)
10 to 25 Hz

DESCRIPTION

The S.T.C. mount comprises a rubber ring bonded to a central tube.

- Inner tube : mild steel.
- Bonded rubber in the form of a ring at the top with a collar below which is used for fixing.

OPERATION

The design of the S.T.C. mount gives the following basic characteristics :

- The rubber works in compression.
- Anti-rebound.
- Can be used as safety mounting.

Advantages :

- Simple to fix.
- Simple and economical.
- Extensive range of loads.

(1) Natural frequencies with max/min loads, see : OPERATING CHARACTERISTICS.

DIMENSIONS

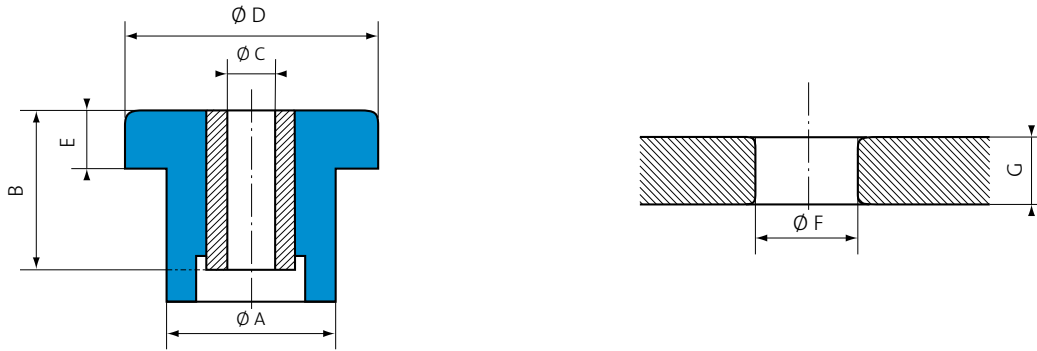

Reference	Ø A (mm)	B (mm)	Ø C (mm)	Ø D (mm)	E (mm)	Ø F (mm)	G (mm)
539887	20,6	17,5	10	27,7	5,6	20,6	8
539190	31,5	25,4	13	44,5	10,4	31,5	10
539886	34,3	35	13	50,8	13,5	34,3	16
539191	41,1	44,5	16	63,5	15,7	41,1	19
*539920	38	23	16	64	16	38,5	19
539951	56,6	50,8	20	95	25,4	56	20

* This S.T.C. is mounted in pairs : see shape 2.
See current price list for availability of items.

OPERATING CHARACTERISTICS

Reference	Hard. Shore A	Nominal static load (daN)	Deflection (mm)
539887	45	8-35	0,7
	60	10-50	0,7
539190	45	15-75	1,2
	60	25-100	1,2
539886	60	35-150	1,2
	75	80-330	1,2

Reference	Hard. Shore A	Nominal static load (daN)	Deflection (mm)
539191	60	60-250	2
	75	125-500	2
539920	45	100-400	2
	75	250-1000	1
539951	45	175-700	3
	65	250-1000	3

ASSEMBLY

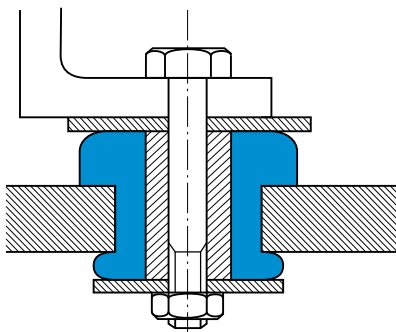

Shape 1

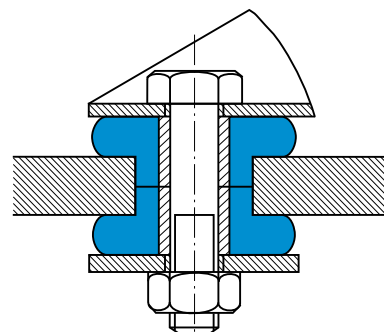

Shape 2 (For 539920)