



Cylindrical
stop

Conical
progressive
stop

LEVAFLEX
progressive
stop

EVIDGOM
stop

STOPS

See :
Supports and
Bump stops

DESCRIPTION

There are several types of stops :

- Cylindrical or DIABOLO stops.
- Conical progressive stops.
- LEVAFLEX progressive stops with central cavity.
- EVIDGOM stops.

OPERATION

The design of the PAULSTRA elastic stops gives the following basic characteristics :

- Highly deformable allowing high energies to be absorbed.
- Progressive absorption of energy due to the carefully designed shape.

Advantages :

- By comparison with rigid stops, PAULSTRA elastic stops are quiet and avoid hammering and deterioration of equipment.

Recommendations :

- The stops must be fitted so that, on impact, the axis of the stop is perpendicular to the contact surface.
- On impact, the external diameter of the stop increases: this must be allowed for when fixing.

DIMENSIONS AND OPERATING CHARACTERISTICS

CYLINDRICAL STOPS

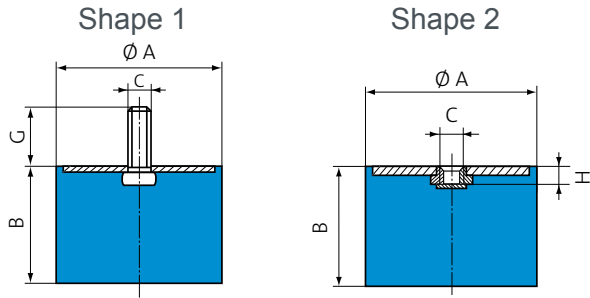

Ø A (mm)	B (mm)	C (mm)	G (mm)	Shape	H (mm)	Max. load (daN)	Deflect. (mm)	Energy (joules)	Reference
12,5	10	M5	10	1	-	12	2	0,12	511110
	13,5					2,5	0,13	511128	
	15					3	0,16	511115	
	20					8	3,5	0,14	511125
	20					8	3,5	0,14	511125
16	10	M4	10	1	-	2	0,20	0,20	511150
	15		1	-	3	0,30	0,30	511151	
	10		2	2,5	2	0,20	0,20	511152	
	15		2	2,5	3	0,30	0,30	511153	
	15		2	2,5	3	0,30	0,30	511153	
20	10	M6	16,5	1	-	20	2	0,20	511292
	15					3	0,30	511294	
	20					4	0,30	511296	
	25					5	0,30	511298	
	25					5	0,30	511298	
25,5	10	M6	18	1	-	80	2	0,80	511158
	15					3,5	1,00	511155	
	20					5	1,20	511159	
	30					8	2,00	511160	
	15					2	4	60	3,5
20	2	4	55	5,5	1,20	511162			
30	2	4	50	8	2,00	511163			

Ø A (mm)	B (mm)	C (mm)	G (mm)	Shape	H (mm)	Max. load (daN)	Deflect. (mm)	Energy (joules)	Reference
25,5	10	M8	20	1	-	80	2	0,80	511265
	15					3,5	1,00	511270	
	19					4,5	1,20	511251	
	22					5,5	1,30	511275	
	25					6	1,50	511280	
	30					8	2,00	511285	
	40					10	2,50	511290	
30	22	M8	25	1	-	80	6	2,40	511156
	15					90	3,5	1,50	511308
	22					80	6	2,40	511310
	30					70	8	2,80	511312
	40					60	9	2,70	511314
40	30	M8	20	1	-	120	7	4,60	511157
	40					120	10	6,00	511161
	20					160	5	4,00	511450
	25					150	6	4,50	511401
	35					120	8	4,80	511452
50	35	M10	25	1	-	120	10	6,00	511454
	45					120	11	6,60	511456
	25					300	6	9,00	511525
	35					250	9	11,20	511535
	45					190	11	10,00	511545
60	25	M10	25	1	-	400	6	12,00	511625
	36					300	9	13,50	511635
	45					250	11	13,70	511645
70	35	M10	25	1	-	450	9	20,00	511735
	50					350	12	21,00	511750
	70					300	14	21,00	511770
80	25	M14	35	1	-	1100	6	33,00	513801
	30					950	8	38,00	511830
	40					600	10	30,00	511840
	70					500	17	42,50	511870
80	35	450	19	43,00	511880				

See current price list for availability of items.

CONICAL PROGRESSIVE STOPS

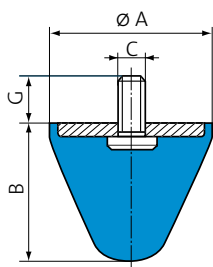

Reference	Ø A (mm)	B (mm)	C (mm)	G (mm)	Repetitive shocks			Exceptional shock energy (joules)	Weight (g)
					Energy (joules)	Deflect. (mm)	Reaction (daN)		
512251	25,5	19	M8	20	3	8	100	9	20
512307	30	30	M8	25	6	15	140	18	37
512301	30	30	M6	13,5	6	15	140	18	30
512515	50	50	M10	25	30	25	340	90	85
512501	50	50	M8	20	30	25	340	90	75
512516	50	64	M10	25	40	32	370	120	150
512502	50	64	M8	35	40	32	370	120	150
512517	50	58	M10	25	37	28	400	110	130
512503	50	58	M8	15	37	28	400	110	120
512608	60	40	M10	25	27	18	550	70	140
512601	60	40	M14	62	27	18	550	70	200
512700	72	58	M10	25	50	26	550	150	290
512721	72	58	M12	30	50	26	550	150	300
512951	95	80	M16	45	120	37	1100	350	750

See current price list for availability of items.

DIABOLO STOPS

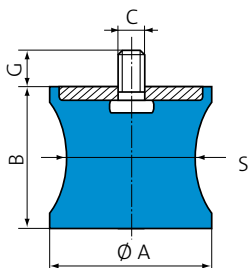

Reference	S (cm²)	Ø A (mm)	B (mm)	C (mm)	G (mm)	Max. inst. load (daN)	Deflect. (mm)	Max. static load (daN)	Deflect. (mm)	Energy (joules)	Weight (g)
511571	5	57	42	M8	20	100	10	40	4	1	60
511572	9,5	57	42	M8	20	200	12	75	5,5	2	80
511601	19,5	60	57	M10	25	350	15	150	8	6	190
511801	38,5	80	65	M14	30	800	16	300	9,5	15	500
511951	50	95	70	M16	35	1000	18	400	9,5	20	790

LEVAFLEX PROGRESSIVE STOPS

Reference	A (mm)	B (mm)	Ø C (mm)	D (mm)	Ø E (mm)	Ø G (mm)	H (mm)	Weight (g)
514085	85	85	8,5	69	8,5	20	5	600
514110	110	110	12,5	90	8,5	30	6	1200
514130	130	130	19	106	11	40	6	2000
514160	160	160	23	132	11	45	8	3000
514200	200	200	28	168	13	60	10	7000

See current price list for availability of items.

Repetitive shocks			Exceptional shock energy (joules)	Reference hardness
Energy (joules)	Corresponding deflection (mm)	Reaction (daN)		
170	40	1200	500	514085/60
280	40	1700	850	514085/75
330	50	1800	1000	514110/60
550	50	3400	1500	514110/75
600	65	2800	1800	514130/60
650	60	3000	1900	514130/75
1050	75	4500	3000	514160/60
1200	90	4000	3600	514200/60
1300	70	6000	3900	514160/75
2200	85	7800	6600	514200/75

See current price list for availability of items.

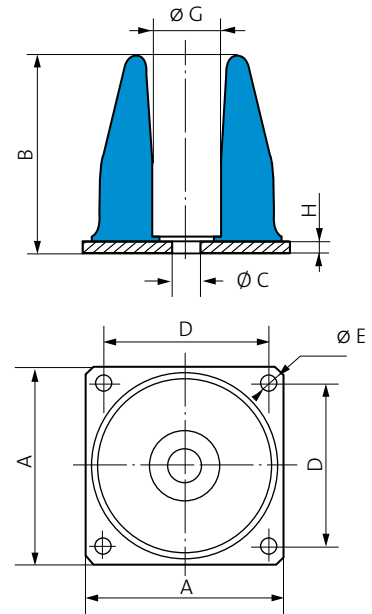

EVIDGOM STOPS

Repetitive shocks			Exceptional shock energy (joules)	Reference
Energy (joules)	Corresponding deflection (mm)	Reaction (daN)		
31	30	190	95	810644
100	50	580	300	810645
110	45	600	330	810666
180	67	750	540	810642
350	75	1250	1050	810653
360	65	1400	1100	810655
400	85	1500	1200	810669
300	70	900	-	810784
600	75	1625	-	810775
1050	90	2375	-	810776
2500	90	5500	-	810733/60
7100	150	11000	-	810732/60
9500	200	9500	-	810731/60
13000	130	18000	-	810732/75
17500	175	19000	-	810731/75
21000	200	25000	-	810735/60
29000	250	35000	-	810734/60
41000	200	70000	-	810735/75
50000	250	55000	-	810734/75

Stop reference	Shape	All rubber Évidgom reference	Ø A (mm)	B (mm)	C	Ø C1 (mm)	Ø C2 (mm)	Ø D (mm)	Ø A under load (mm)
810642	1	810022	85	120	M16	20	30	-	114
810644	1	810004	55	55	M10	14	14	-	72
810645	2	810035	66	93	M16	20	14	-	100
810653	1	810023	100	130	M16	20	30	-	140
810655	1	810025	110	132	M16	20	30	-	142
810666	2	810046	76	90	M16	20	14	-	98
810669	2	810029	110	150	M16	20	30	-	155
810731	3	-	250	400	6 x M24	70	70	150	360
810732	3	-	250	315	6 x M24	70	70	150	380
810733	3	-	250	230	6 x M24	70	70	150	370
810734	3	-	350	500	8 x M24	85	85	196	445
810735	3	-	350	395	8 x M24	85	85	196	500
810775	1	810015	155	150	M16	25	30	-	202
810776	1	810016	188	180	M24	40	40	-	256
810784	1	810014	125	140	M16	30	25	-	168

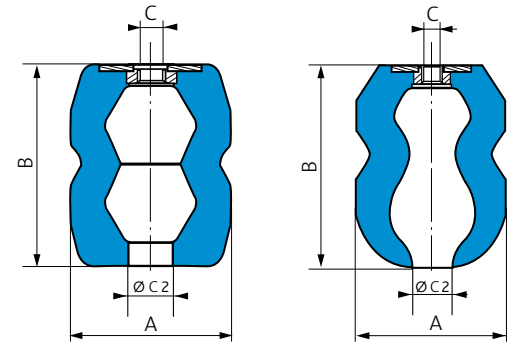

Shape 1

Shape 2

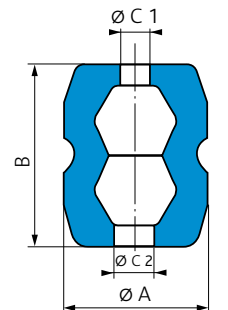

Shape 3

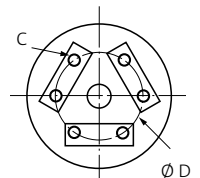

NOTE : The values are given for test conditions with an impact speed of 1 m/s. Consult us for speeds that are much higher.

DEFLECTION CURVES AND ENERGY VALUES FOR PROGRESSIVE, LEVAFLEX AND EVIDGOM STOPS

