



## V47 V47D V47T V47Q

Natural frequency : (1)  
8 to 20 Hz

### DESCRIPTION

- Anti-vibration mount available with a constant natural frequency over a wide load range.
- Cast iron base and levelling device.
- Conical wire mesh cushion, capable of narrying lateral loads.
- V47D version has a stack of two cushions with a cast iron separating cup.
- V47T and V47Q have three and four metal cushions respectively.

### APPLICATIONS

This machinery mount, with adjustable height, is used for machine tools and other rotating machine. The V47 and V47D are designed for presses and printing machines.

(1) Natural frequencies with max/min loads, see : OPERATING CHARACTERISTICS.

# DIMENSIONS

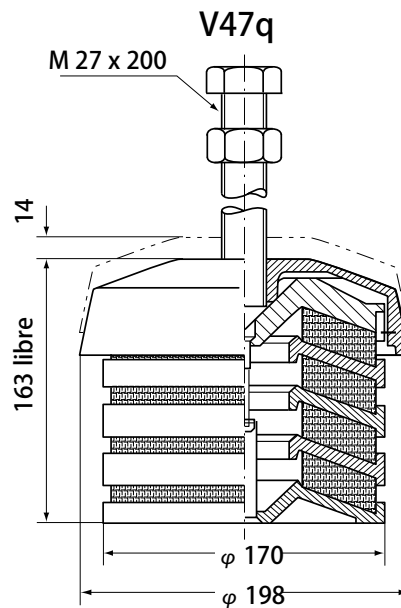
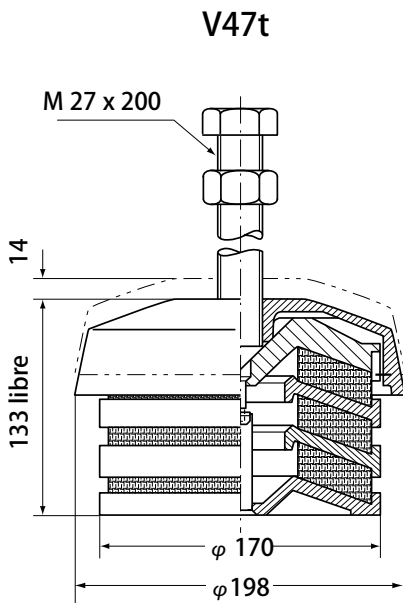
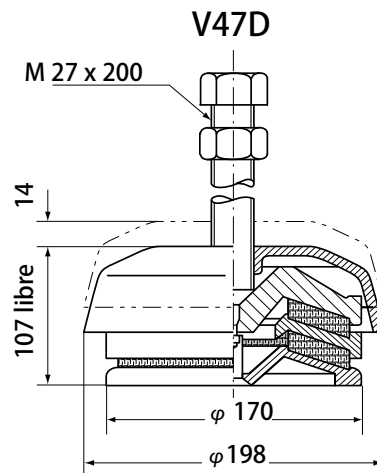
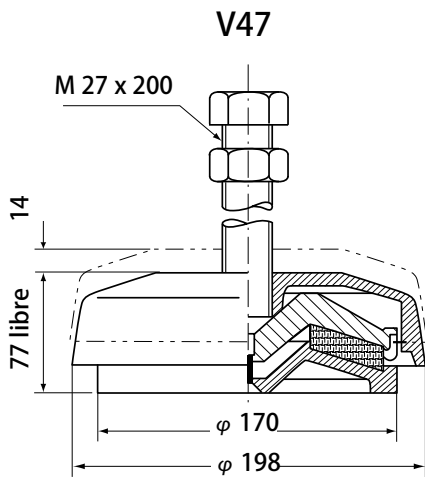

# OPERATING CHARACTERISTICS

Reference	Load range (daN)	Max. dynamic force (daN)	Natural frequency (Hz)	Weight of mounting (Kg)
V47	250 to 7 000	21 000	15 to 20	9,1
V47D	250 to 7 000	21 000	12 to 16	12,2
V47T	250 to 7 000	21 000	10 to 13	13,1
V47Q	250 to 7 000	21 000	8 to 11	15,1